

Short-stroke cylinder, Series SSI

- ISO 15524
- Ø 12-100 mm
- Ports M5 G 1/8 G 1/4 G 3/8
- double-acting
- Cushioning elastic
- Piston rod Internal thread

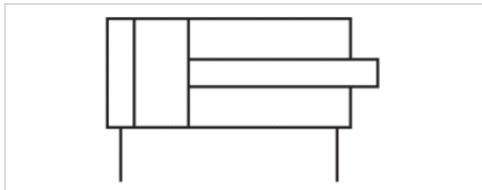

Standards	ISO 15524
Compressed air connection	Internal thread
Ambient temperature min./max.	-20 ... 80 °C
Medium temperature min./max.	-20 ... 80 °C
Medium	Compressed air
Max. particle size	50 µm
Oil content of compressed air	0 ... 5 mg/m ³
Pressure for determining piston forces	6.3 bar

Technical data

Piston Ø Piston rod thread Ports Piston rod Ø	12 mm M3 M5 6 mm	16 mm M4 M5 8 mm	20 mm M5 M5 10 mm	25 mm M6 M5 12 mm	32 mm M8 G 1/8 16 mm	40 mm M8 G 1/8 16 mm
Stroke 5	R480637830	R480637835	R480637841	R480637849	R480637857	R480637865
10	R480637831	R480637836	R480637842	R480637850	R480637858	R480637866
15	R480637832	R480637837	R480637843	R480637851	R480637859	R480637867
20	R480637833	R480637838	R480637844	R480637852	R480637860	R480637868
25	R480637834	R480637839	R480637845	R480637853	R480637861	R480637869
30	-	R480637840	R480637846	R480637854	R480637862	R480637870
40	-	-	R480637847	R480637855	R480637863	R480637871
50	-	-	R480637848	R480637856	R480637864	R480637872
80	-	-	-	-	R480644580	R480641942
100	-	-	-	-	R480644582	R480644583

Piston Ø Piston rod thread Ports Piston rod Ø	50 mm M10 G 1/4 20 mm	63 mm M10 G 1/4 20 mm	80 mm M16 G 3/8 25 mm	100 mm M20 G 3/8 32 mm
Stroke 5	R480637873	R480637883	R480637893	R480637903
10	R480637874	R480637884	R480637894	R480637904
15	R480637875	R480637885	R480637895	R480637905
20	R480637876	R480637886	R480637896	R480637906
25	R480637877	R480637887	R480637897	R480637907
30	R480637878	R480637888	R480637898	R480637908
40	R480637879	R480637889	R480637899	R480637909
50	R480637880	R480637890	R480637900	R480637910
80	R480637881	R480637891	R480637901	R480637911
100	R480637882	R480637892	R480637902	R480637912

Technical data

Piston Ø	12 mm	16 mm
Retracting piston force	53 N	95 N
Extracting piston force	71 N	127 N
Impact energy	0,03 J	0,06 J
Weight 0 mm stroke	0,023 kg	0,039 kg
Weight +10 mm stroke	0,012 kg	0,017 kg
Working pressure min./max.	1 ... 10 bar	1 ... 10 bar
Material, front cover	Brass	Brass
Scraper material	Nitrile butadiene rubber	Nitrile butadiene rubber
Stroke max.	75 mm	100 mm

Piston Ø	20 mm	25 mm
Retracting piston force	148 N	238 N
Extracting piston force	198 N	309 N
Impact energy	0,08 J	0,1 J
Weight 0 mm stroke	0,052 kg	0,071 kg
Weight +10 mm stroke	0,02 kg	0,027 kg
Working pressure min./max.	1 ... 10 bar	1 ... 10 bar
Material, front cover	Brass	Aluminum
Scraper material	Nitrile butadiene rubber	Nitrile butadiene rubber
Stroke max.	150 mm	150 mm

Piston Ø	32 mm	40 mm
Retracting piston force	380 N	665 N
Extracting piston force	507 N	792 N
Impact energy	0,16 J	0,24 J
Weight 0 mm stroke	0,11 kg	0,193 kg
Weight +10 mm stroke	0,038 kg	0,044 kg
Working pressure min./max.	0,6 ... 10 bar	0,6 ... 10 bar
Material, front cover	Aluminum	Aluminum
Scraper material	Nitrile butadiene rubber	Nitrile butadiene rubber
Stroke max.	150 mm	150 mm

Piston Ø	50 mm	63 mm	80 mm	100 mm
Retracting piston force	1039 N	1766 N	2857 N	4441 N
Extracting piston force	1237 N	1964 N	3167 N	4948 N
Impact energy	0,32 J	0,38 J	0,43 J	0,5 J
Weight 0 mm stroke	0,312 kg	0,523 kg	0,97 kg	1,83 kg
Weight +10 mm stroke	0,067 kg	0,079 kg	0,122 kg	0,168 kg
Working pressure min./max.	0,6 ... 10 bar	0,6 ... 10 bar	0,6 ... 10 bar	0,6 ... 10 bar
Material, front cover	Aluminum	Aluminum	Aluminum	Aluminum
Scraper material	Polyurethane	Polyurethane	Polyurethane	Polyurethane
Stroke max.	150 mm	150 mm	150 mm	150 mm

Technical information

The pressure dew point must be at least 15 °C under ambient and medium temperature and may not exceed 3 °C .

The oil content of compressed air must remain constant during the life cycle.

Use only the approved oils from AVENTICS. Further information can be found in the "Technical information" document (available in the MediaCentre).

Note the selection of fittings for strokes 10 mm .

Technical information

Material	
Cylinder tube	Aluminum, anodized
Piston rod	Stainless steel
Front cover	Brass Aluminum
End cover	Aluminum
Seal	Nitrile butadiene rubber
Scraper	Nitrile butadiene rubber Polyurethane
	See table for additional data on materials.

Dimensions

Dimensions

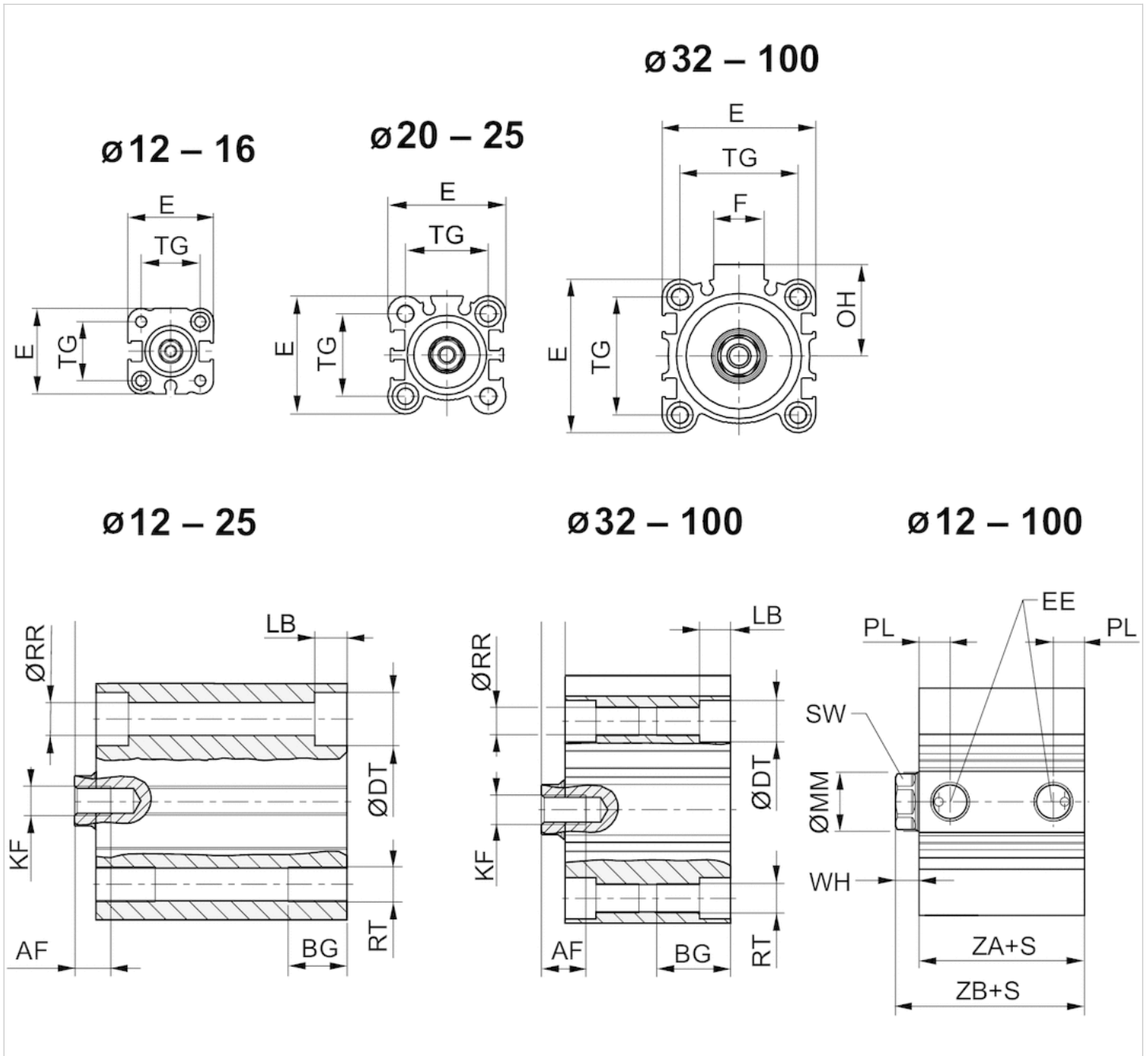

S = stroke

Dimensions

Piston Ø	AF	BG	ØDT	E	EE	F	KF	LB max.	ØMM f8	OH	ØRR	RT	SW	TG
12 mm	6	7	6.5	25	M5	-	M3	3.5	6	-	3.7	M4	5	15,5 ±0,3
16 mm	8	7	6.5	29	M5	-	M4	3.5	8	-	3.7	M4	7	20 ±0,3
20 mm	7	10	9	36	M5	-	M5	5.5	10	-	5.55	M6	8	25,5 ±0,3
25 mm	12	10	9	40	M5	-	M6	5.5	12	-	5.55	M6	10	28 ±0,3
32 mm	13	16	9	45	G 1/8	17	M8	5.5	16	27	5.55	M6	13	34 ±0,3
40 mm	13	16	9	52	G 1/8	17	M8	5.5	16	31	5.55	M6	13	40 ±0,3

Piston Ø	AF	BG	ØDT	E	EE	F	KF	LB max.	ØMM f8	OH	ØRR	RT	SW	TG
50 mm	15	20	11	64	G 1/4	21	M10	8	20	39	7.4	M8	17	50 ±0,5
63 mm	15	25	14	77	G 1/4	21	M10	10.5	20	45.5	9.3	M10	17	60 ±0,5
80 mm	21	30	17.5	98	G 3/8	26	M16	13.5	25	59	11.2	M12	22	77 ±0,5
100 mm	27	30	17.5	117	G 3/8	26	M20	13.5	32	65	11.2	M12	27	94 ±0,5

Piston Ø	WH	S	PL	ZA±0,2	ZB±2
12 mm	3,5 ±1,5	2-4 ≥5	4,5 5,5	17	20.5
16 mm	3,5 ±1,5	≥2	5.5	18.5	22
20 mm	4,5 ±1,5	≥2	5.5	19.5	24
25 mm	5 ±1,5	≥2	5.5	22.5	27
32 mm	7 ±2	2-4 ≥5	6,3 7,5	23	30
40 mm	7 ±2	≥2	7.5	29.5	36.5
50 mm	8 ±2	2-8 ≥9	8,2 10,5	30.5	38.5
63 mm	8 ±2	≥2	10.5	36	44
80 mm	10 ±2	≥2	12.5	43.5	53.5
100 mm	12 ±2,5	≥2	14	53	65