

Compact Proportional Solenoid Valve



Repeatability:
3 % or less

Hysteresis:
10 % or less

Fluid	Flow rate control range <small>Note)</small>	Series
Air	0 to 6 l/min	PVQ10
	0 to 100 l/min	PVQ30

Note) Varies depending on the model.



Control the flow rate smoothly according to the current

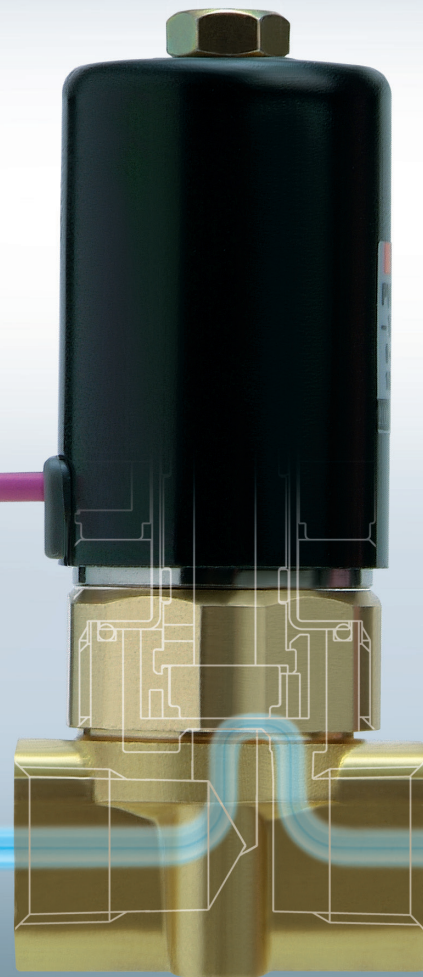
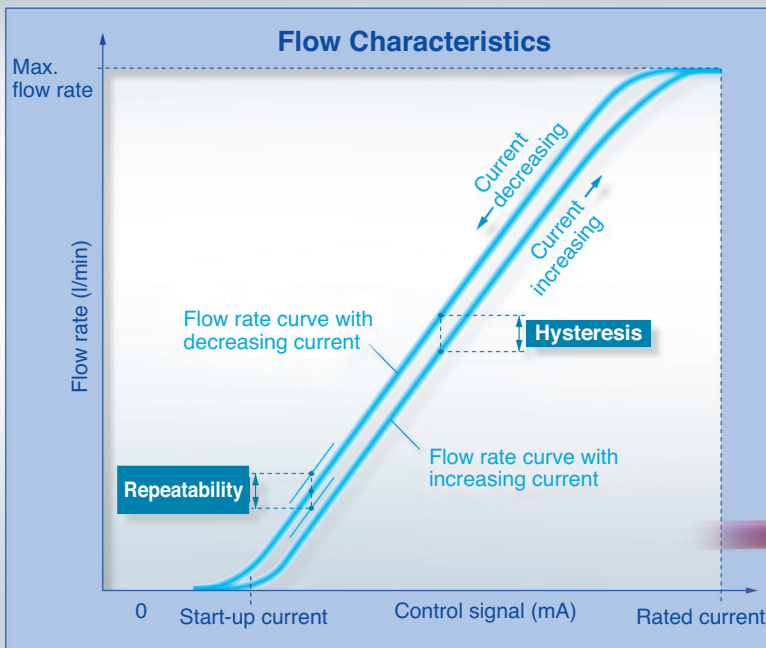

Series **PVQ**

- **Service life: Lasts 25 million cycles.** (PVQ30)
(SMC in-house life test conditions)

Specially coated sliding surface realised 25 million cycles within a set operation range

- **Body material: Brass (C36)** (PVQ10),
Brass (C37) or Stainless steel (PVQ30)

Seal material: FKM (PVQ10, PVQ30)

- **Valve returns to closed position when power supply is turned off.**

- **Leakage amount: 5 cm³/min or less at OFF**

- **Can be used for vacuum applications.** (Minimum operating pressure 0.1 Pa-abs)

- **Operation noise during opening/closing of the valve reduced**

PVQ10	ON	25.6 to 29.1 dB	PVQ30	ON	38.9 to 42.4 dB
	OFF	28.6 to 31.6 dB		OFF	48.4 to 49.7 dB

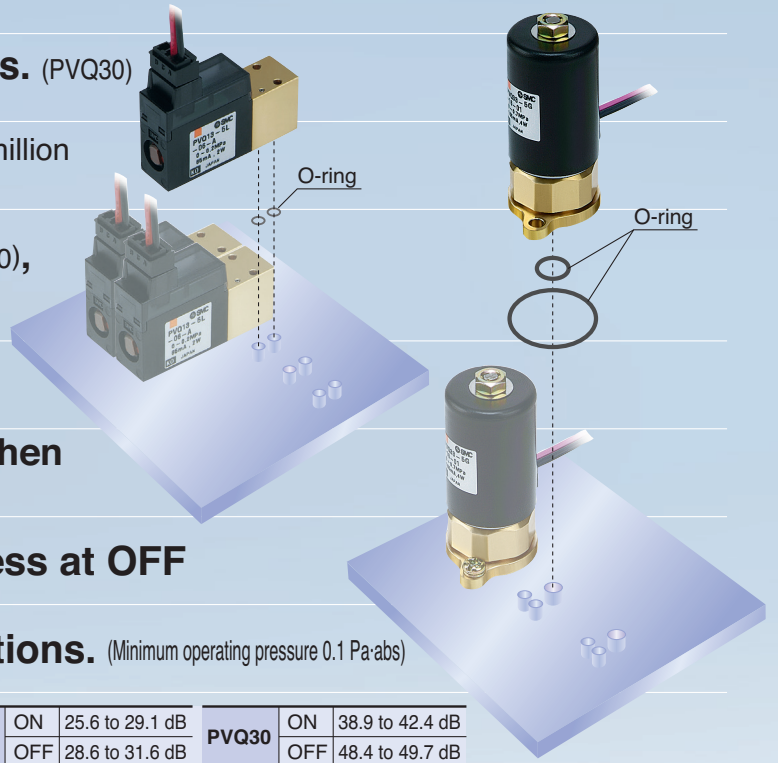

Working Principle

The armature is attracted to the core by an electromagnetic force as the coil is energised. When the applied current varies, the attraction force also varies proportionally to it. The flow rate is controlled by the movement (stroke) of the armature, depending on the balance between the attraction force and the spring load.

Note) Sliding resistance at this point is the hysteresis of the flow.

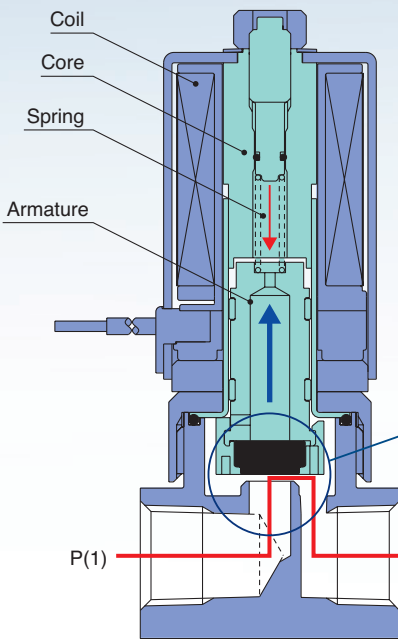

PVQ30

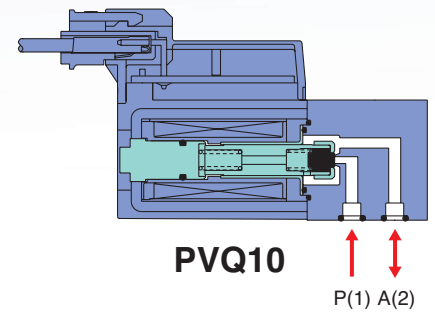
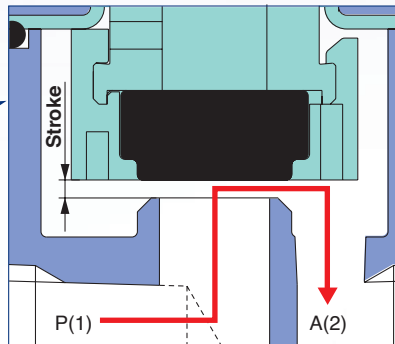

Proportional Solenoid Valve

Flow rate can be controlled smoothly with one proportional solenoid valve by current control.

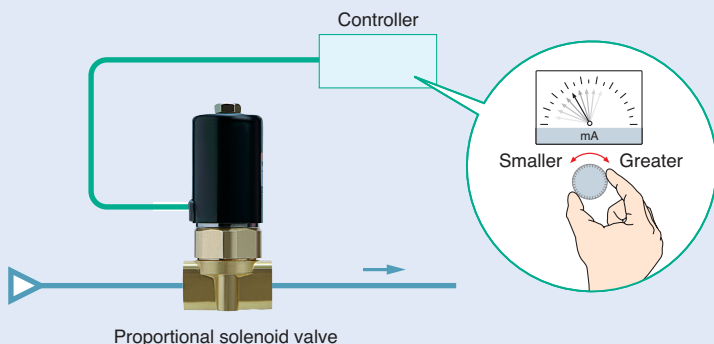

Conventional (2 port valve)

One 2-port valve is required for each flow rate.

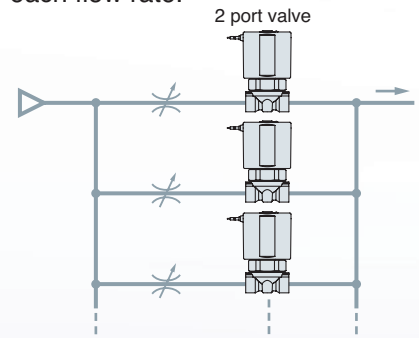

Applications

Air-blow

- Blow-off of debris or water.
- Work transportation

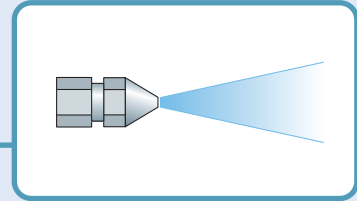

Spin control of handpiece

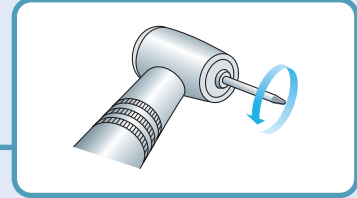

Blood pressure gauge

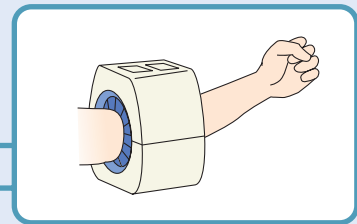

Vacuum chamber supply flow control

Smooth air supply/exhaust is possible by reducing the initial air supply. Prevents dust being stirred up inside the chamber.

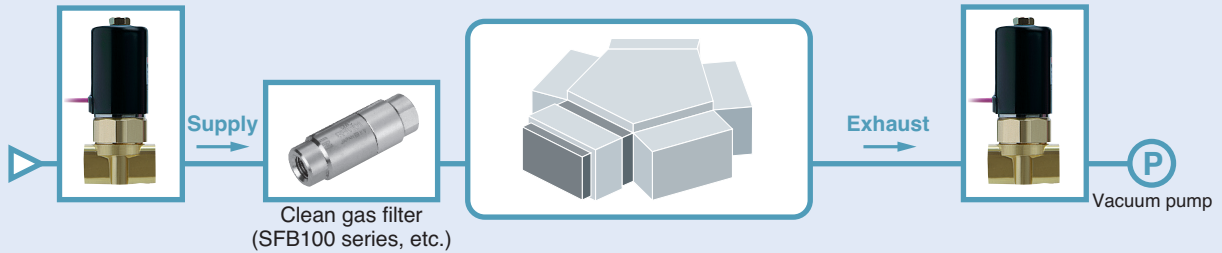

Model	PVQ13				PVQ31		PVQ33	
Piping type	Base mounted				Body ported		Base mounted	
Valve construction	Direct operated poppet				Direct operated poppet			
Valve type	N.C.				N.C.			
Orifice size (mm)	0.3	0.4	0.6	0.8	1.6	2.3	4	
Max. operating pressure differential (MPa)	0.7	0.45	0.2	0.1	0.7	0.35	0.12	
Flow rate (l/min)	0 to 5	0 to 6		0 to 5	0 to 100		0 to 75	
Applied current (Power supply)	0 to 85 mA (24 VDC) 0 to 170 mA (12 VDC)				0 to 165 mA (24 VDC) 0 to 330 mA (12 VDC)			
Port size	M5				1/8			

Series PVQ Model Selection

<To use orifice Ø 1.6 (See PVQ30: Chart 1)>

Condition 1. $P_1 = 0.7 \text{ MPa}$, $P_2 = 0 \text{ MPa}$ (Atmospheric pressure)

Refer to curve A when ΔP is 0.7 MPa.

- Ex) At increasing currents, when a 140 mA current is applied, a flow rate of 85 l/min is achieved. (See ①.)
 If current decreases at this point, the flow rate may not change by 135 mA due to hysteresis. (See ②.)
 The flow rate at an increasing and decreasing current is not the same due to hysteresis. (① 85 l/min., ③ 93 l/min.)

Condition 2. $P_1 = 0.7 \text{ MPa}$, $P_2 = 0.2 \text{ MPa}$

Refer to curve B when ΔP is 0.5 MPa.

- Ex) At increasing currents, when a 150 mA current is applied, a flow rate of 65 l/min is achieved. (See ④.)
 If P_2 increases by 0.15 MPa, ΔP decreases by 0.15 MPa and becomes 0.35 MPa (See curve C), and when the same current is applied the flow rate is 40 l/min. (See ⑤.)

- The flow rate decreases due to a change (increase) in the outlet pressure, even if the inlet pressure and the current value are the same.

Condition 3. Under vacuum pressure

- For vacuum specifications, the operating pressure range is from 0.1 Pa-abs to max. operating pressure differential.
- A(2) port is applicable with vacuum pressure.

<Chart 1> PVQ30 (Ø 1.6)

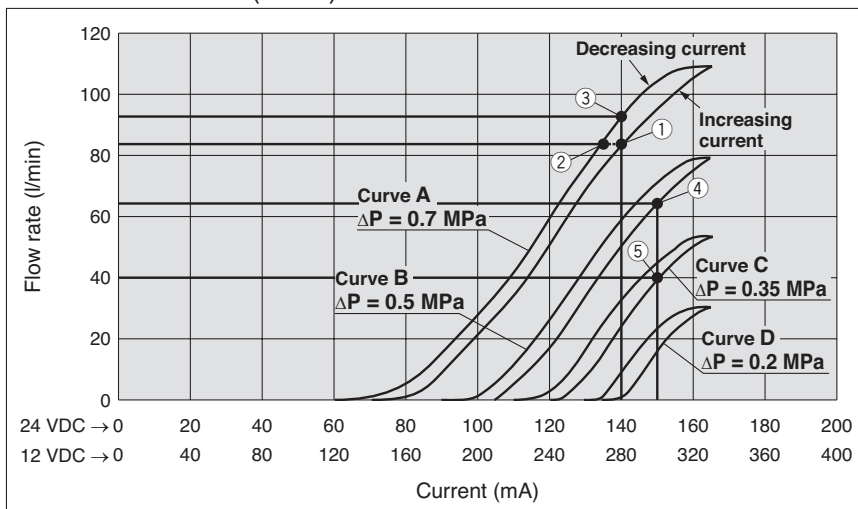

$\Delta P = (P_1 - P_2) \text{ MPa}$
 ΔP : Pressure differential
 P_1 : Inlet pressure
 P_2 : Outlet pressure

● Q. Required flow rate = 0 to 75 l/min.

P_1 = No conditions, P_2 = 0 MPa (Atmospheric pressure)

In this case, all of PVQ30 series orifice sizes satisfy the required flow rate. (Flow rate when rated current is applied)
The table below shows the pressure differentials needed to satisfy the required flow rate. In the flow rate characteristic charts, a pressure differential over the flow rate indicated by the dashed line (75 l/min.) up to the max. operating pressure differential will satisfy the required flow rate.

Table. Pressure differential needed to satisfy the required flow rate = 0 to 75 l/min.

	Ø 1.6	Ø 2.3	Ø 4.0
Pressure differential (ΔP)	0.5 to 0.7 MPa	0.25 to 0.35 MPa	0.12 MPa

$\Delta P = (P_1 - P_2)$ MPa
 ΔP : Pressure differential
 P_1 : Inlet pressure
 P_2 : Outlet pressure

PVQ30 (Ø 1.6)

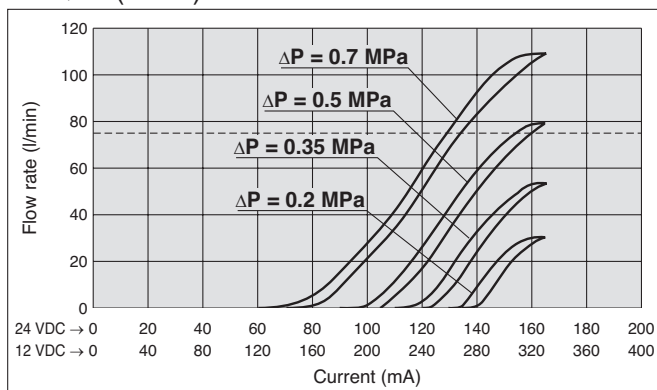

PVQ30 (Ø 2.3)

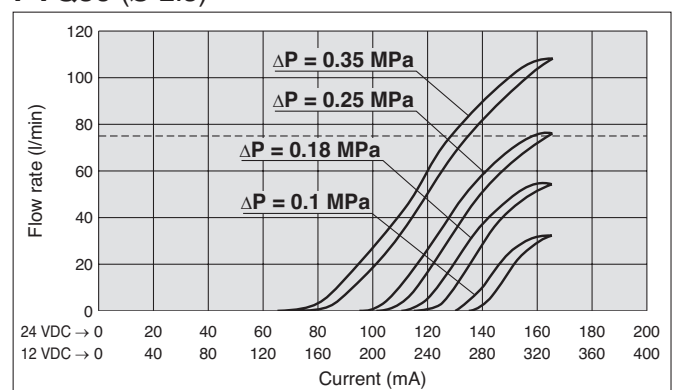

PVQ30 (Ø 4.0)

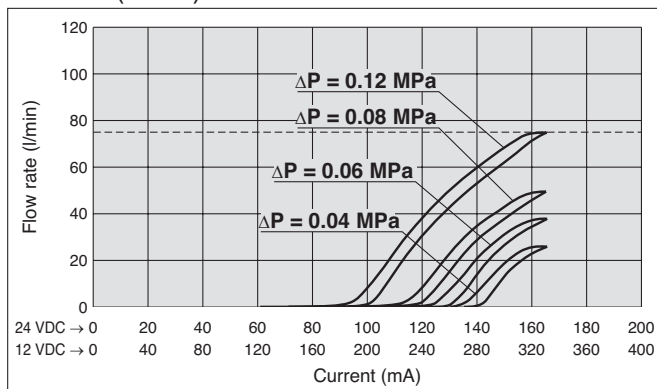

● Note

- 1) For this product, the max. operating pressure differential varies by orifice diameter.
Operate at a pressure differential which is 20 % or more of the max. operating pressure differential.
If the product must be operated at a pressure differential which is less than 20 % of the max. operating pressure differential, either change the size of the orifice or change to a size from the PVQ10 series.
- 2) The smaller the pressure differential the product is operating at is in relation to the max. operating pressure differential, the smaller the controllable flow rate range and electric current range will be. This may result in reduced controllability, and hunting phenomenon or valve opening failure may occur.
- 3) If this product is used for the charging and discharging of a tank, the valve pressure differential may get smaller due to pressure fluctuations in the tank, which may result in valve opening failure.
- 4) Flow rate depends on individual differences between valves and piping conditions. Refer to flow rate characteristics chart to select the model with adequate margin for required flow rate.
- 5) Follow the same procedure for selecting PVQ10 series.

Compact Proportional Solenoid Valve

Series PVQ10



How to Order

Base mounted



PVQ 13-5 L □-03-M5-A

Valve type

13	N.C.
----	------

Voltage

5	24 VDC
6	12 VDC

Electrical entry

L	L plug connector	
M	M plug connector	

With / Without lead wire

-	With lead wire
O	Without lead wire

Body / Seal material

Symbol	Body	Seal
A	Brass (C36)	FKM

Port size

-	Without sub-plate (with mounting screw M1.7 x 17L, 2 pcs.)	
M5	With sub-plate M5 x 0.8	

Orifice size

Symbol	Orifice dia.	Max. operating pressure differential
03	0.3 mmØ	0.7 MPa
04	0.4 mmØ	0.45 MPa
06	0.6 mmØ	0.2 MPa
08	0.8 mmØ	0.1 MPa

Note) For selection, refer to Model Selection on pages front matter 1 and front matter 2.

Specifications

Standard specifications	Valve construction	Direct operated poppet	
	Fluid	Air	
	Seal material	FKM	
	Body material	Brass (C36)	
	Fluid temperature	0 to +50 °C	
	Ambient temperature	0 to +50 °C	
	Action	N.C. (Normally closed)	
	Mounting orientation	Unrestricted	
	Port size	M5	
	Coil specifications	Power supply	24 VDC
Coil current		0 to 85 mA	0 to 170 mA
Power consumption		0 to 2 W	
Coil insulation		Class B	

Characteristic specifications	Orifice diameter (mmØ)	0.3	0.4	0.6	0.8
	Max. operating pressure differential (MPa) ^{Note 1)}	0.7	0.45	0.2	0.1
	Max. operating pressure (MPa)	1			
	Min. operating pressure (MPa) (Vacuum) ^{Note 2)}	0 (0.1 Pa.abs)			
	Flow rate (l/min) (at max. operating pressure differential)	0 to 5	0 to 6		0 to 5
	Hysteresis (at max. operating pressure differential)	10 % or less			
	Repeatability (at max. operating pressure differential)	3 % or less			
	Start-up current (at max. operating pressure differential)	50 % or less			

Note 1) Maximum operating pressure differential indicates pressure differential (difference between the inlet and outlet pressure) which can be allowed for operation with the valve closed or open. If the pressure differential exceeds the max. operating pressure differential of orifice, the valve may leak.

Note 2) For vacuum applications, the max. operating pressure range is 0.1 Pa-abs to max. operating pressure differential. A(2) port is applicable for vacuum pressure.

Flow Characteristics

PVQ10 (Ø 0.3)

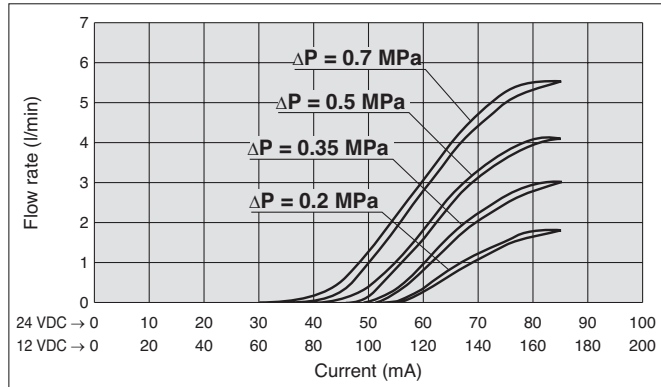

PVQ10 (Ø 0.4)

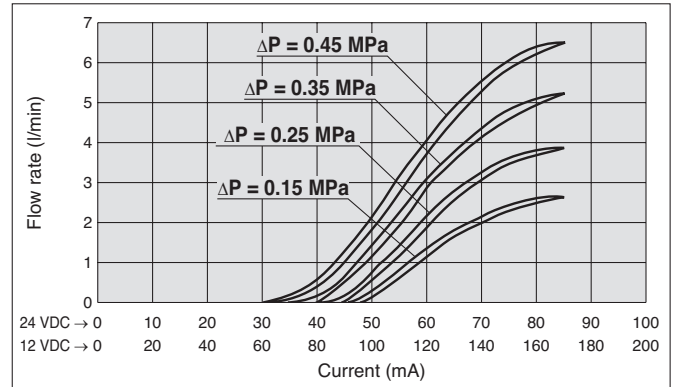

PVQ10 (Ø 0.6)

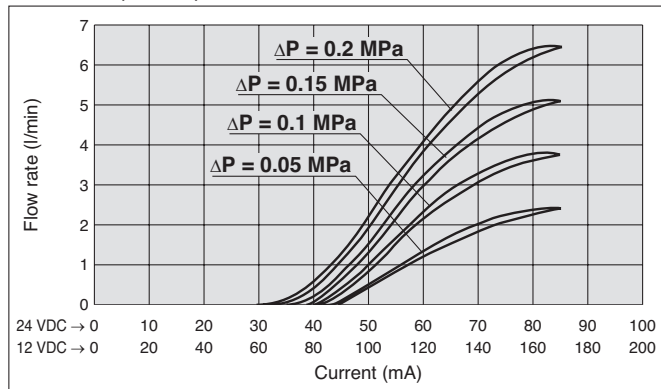

PVQ10 (Ø 0.8)

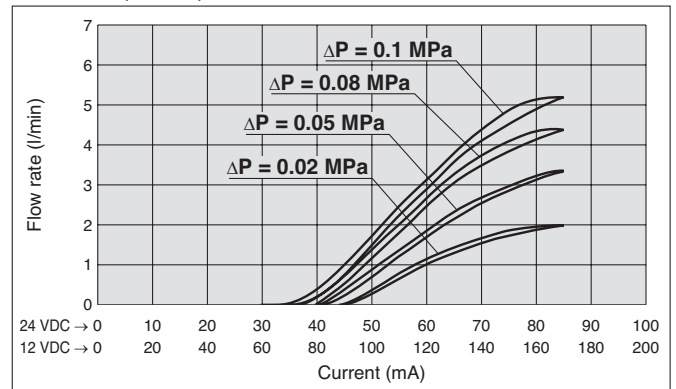

Construction

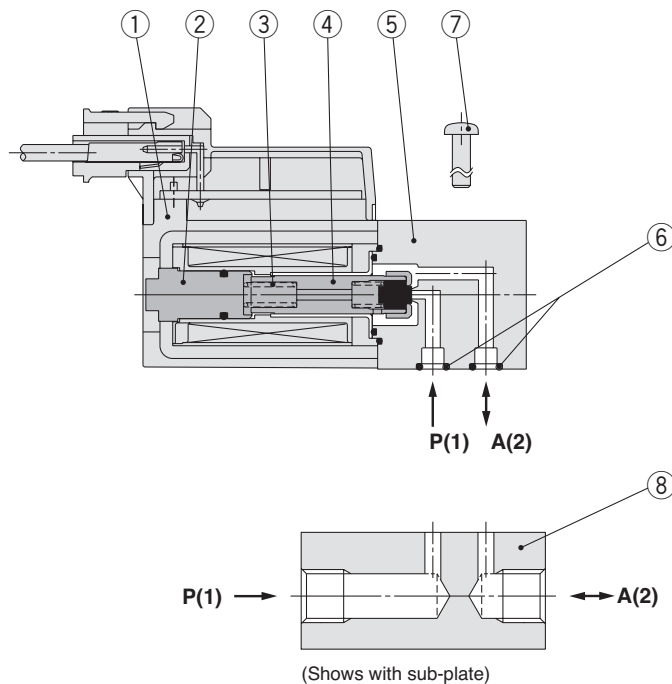

Component Parts

No.	Description	Material	Note
1	Solenoid coil assembly	—	
2	Core	Stainless steel	
3	Return spring	Stainless steel	
4	Armature assembly	Stainless steel, Aluminium, FKM	
5	Body	Brass (C36)	
6	O-ring	FKM	
7	Round head combination screw	Steel	M1.7 x 0.35 x 17L, 2 pcs.
8	Sub-plate	Brass (C37)	Part no. PVQ10-15-M5

Series PVQ10

Dimensions

L plug connector PVQ13-□L-□-M5

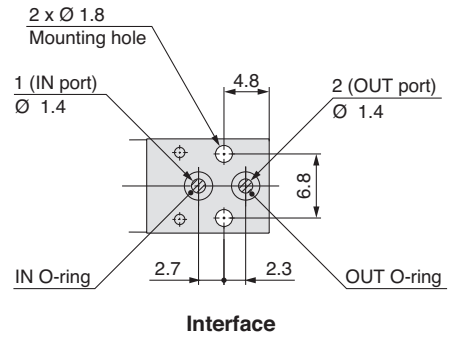
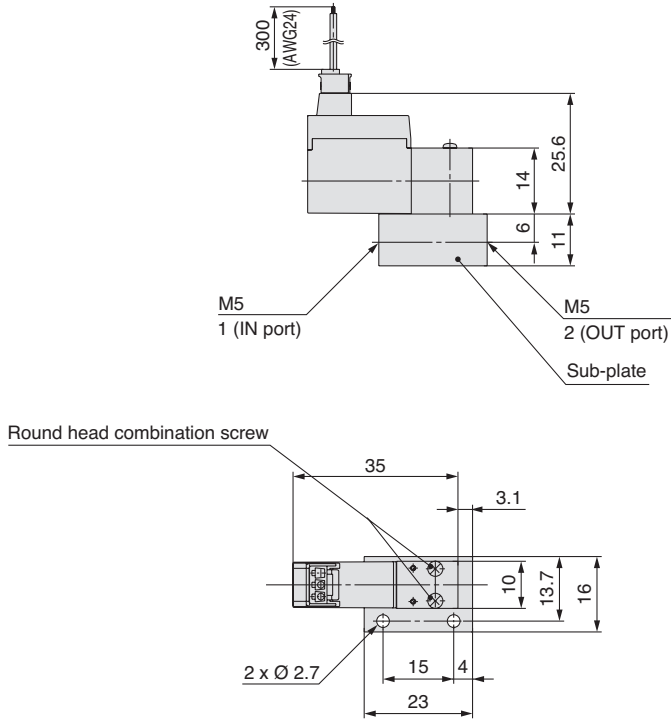

M plug connector PVQ13-□M-□-M5

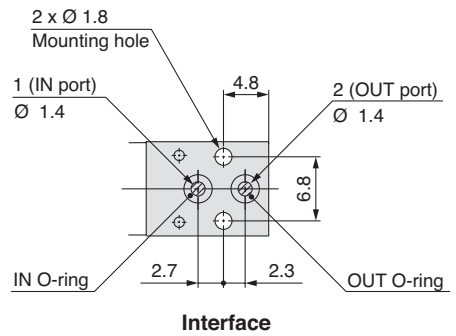
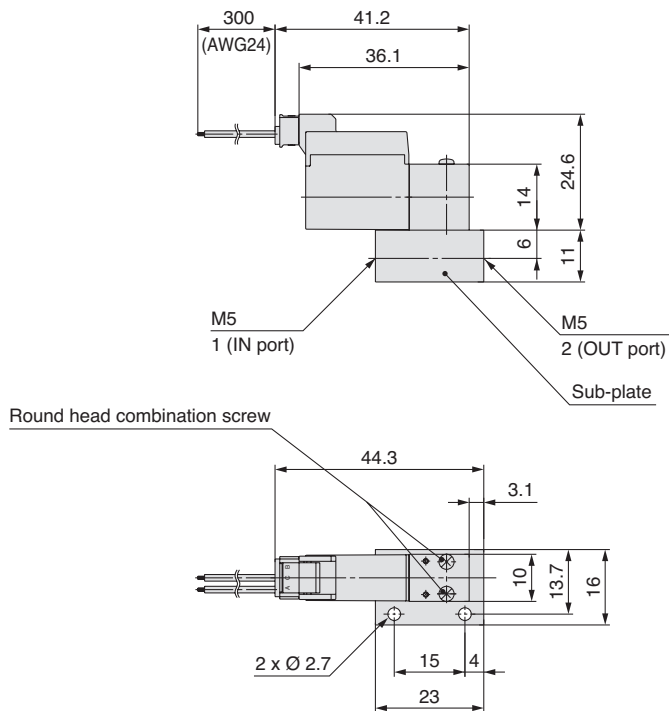

Compact Proportional Solenoid Valve Series PVQ30



How to Order

Body ported



Base mounted

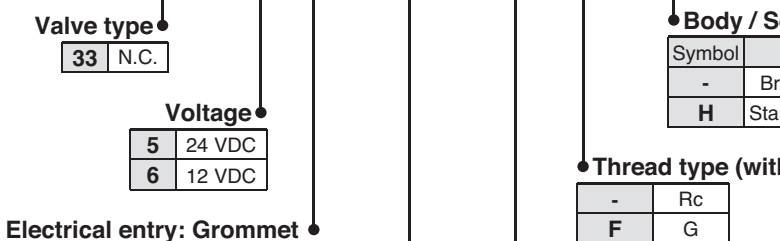

Option

-	None
F	Foot bracket

* Bracket is not mounted but is provided at the time of shipment.

Body / Seal material

Symbol	Body	Seal
-	Brass (C37)	FKM
H	Stainless steel	

Thread type (with sub-plate)

-	Rc
F	G
N	NPT
T	NPTF

Orifice size

Symbol	Orifice dia.	Max. operating pressure differential
16	1.6 mmØ	0.7 MPa
23	2.3 mmØ	0.35 MPa
40	4 mmØ	0.12 MPa

Note) For selection, refer to Model Selection on pages front matter 1 and front matter 2.

Port size

-	Without sub-plate (with mounting screw M3 x 8L, 2 pcs.)	
01	With sub-plate 1/8 (6A)	

Specifications

Standard specifications	Valve construction	Direct operated poppet	
	Fluid	Air	
	Seal material	FKM	
	Body material	Brass (C37, Standard), Stainless steel	
	Fluid temperature	0 to +50 °C	
	Ambient temperature	0 to +50 °C	
	Action	N.C. (Normally closed)	
	Mounting orientation	Unrestricted	
	Enclosure	IP40	
	Port size	Rc 1/8	
Coil specifications	Power supply	24 VDC	12 VDC
	Coil current	0 to 165 mA	0 to 330 mA
	Power consumption	0 to 4 W	
	Coil insulation	Class B	

Characteristic specifications	Orifice diameter (mmØ)	1.6	2.3	4.0
	Max. operating pressure differential (MPa) ^{Note 1)}	0.7	0.35	0.12
	Max. operating pressure (MPa)	1		
	Min. operating pressure (MPa) (Vacuum) ^{Note 2)}	0 (0.1 Pa.abs)		
	Flow rate (l/min) (at max. operating pressure differential)	0 to 100	0 to 75	
	Hysteresis (at max. operating pressure differential)	10 % or less	13 % or less	
	Repeatability (at max. operating pressure differential)	3 % or less		
	Start-up current (at max. operating pressure differential)	50 % or less		

Note 1) Maximum operating pressure differential indicates pressure differential (difference between the inlet and outlet pressure) which can be allowed for operation with the valve closed or open. If the pressure differential exceeds the max. operating pressure differential of orifice, the valve may leak.

Note 2) For vacuum applications, the max. operating pressure range is 0.1 Pa.abs to max. operating pressure differential. A(2) port is applicable for vacuum pressure.

Series PVQ30

Flow Characteristics

Air

PVQ30 (Ø 1.6)

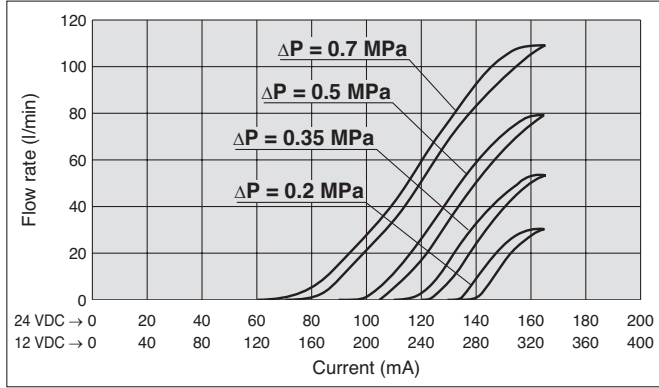

PVQ30 (Ø 2.3)

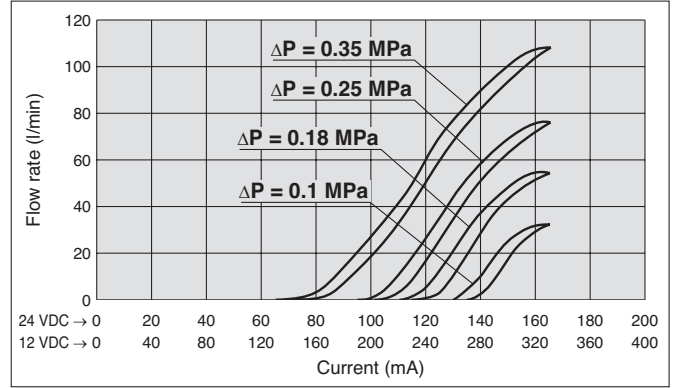

PVQ30 (Ø 4.0)

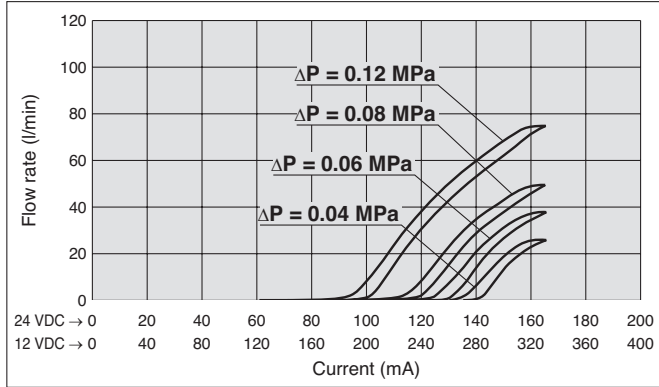

Construction

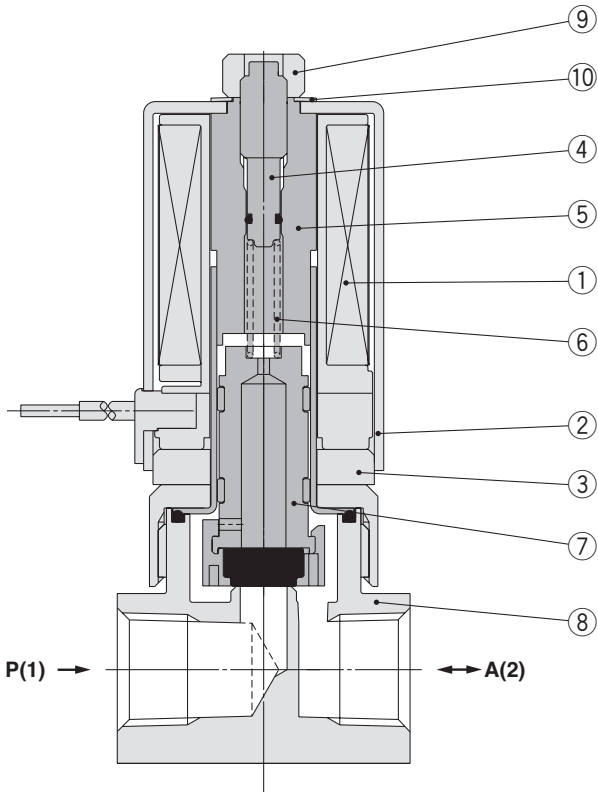

Component Parts

No.	Description	Material	Note
1	Solenoid coil assembly	—	
2	Coil cover	Steel (SPCE)	
3	Magnetic plate	Magnetic iron (SUJ)	
4	Adjusting screw	Stainless steel	
5	Tube assembly	Stainless steel	
6	Return spring	Stainless steel	
7	Armature assembly	Stainless steel, PPS, PTFE, FKM	
8	Body	Brass (C37) or Stainless steel	
9	Nut	Steel	
10	Wave washer	Stainless steel	
11	Round head combination screw	Copper	M3 x 8L 2 pcs.
12	Sub-plate	Brass (C37)	Base mounted only Part no.: PVQ30-15-01□
13	O-ring	FKM	
14	O-ring	FKM	

Option (Body ported only)

• Bracket assembly: VDW20-15A-1

Dimensions

PVQ31

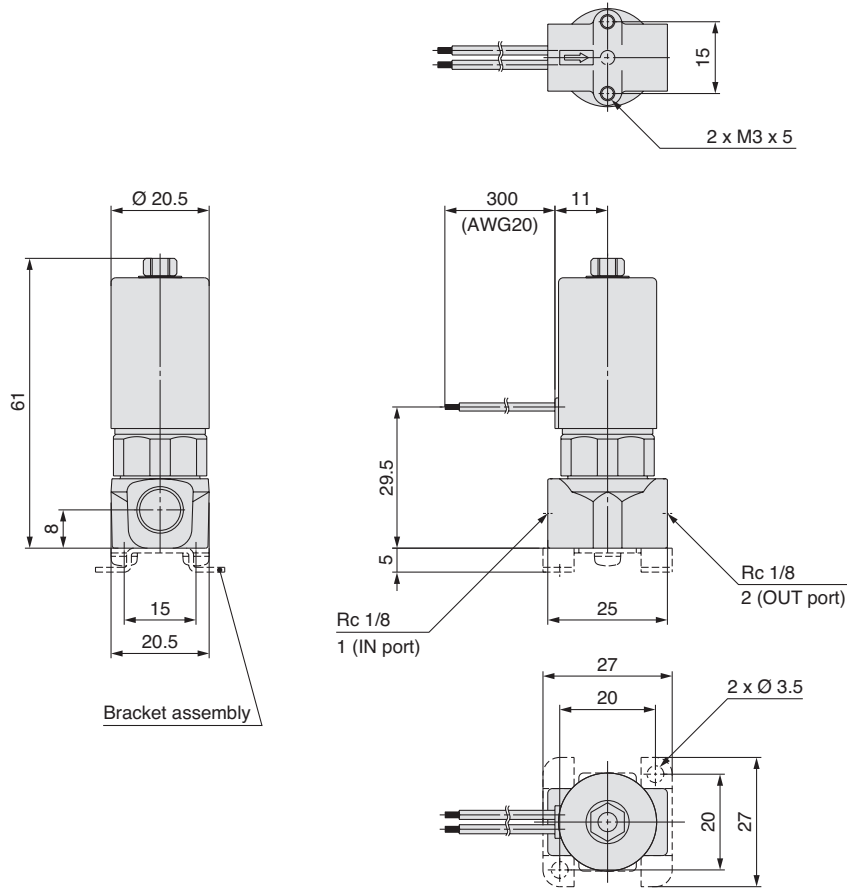

PVQ33

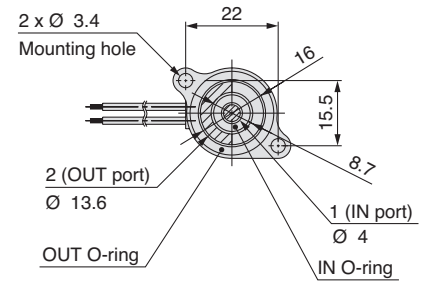
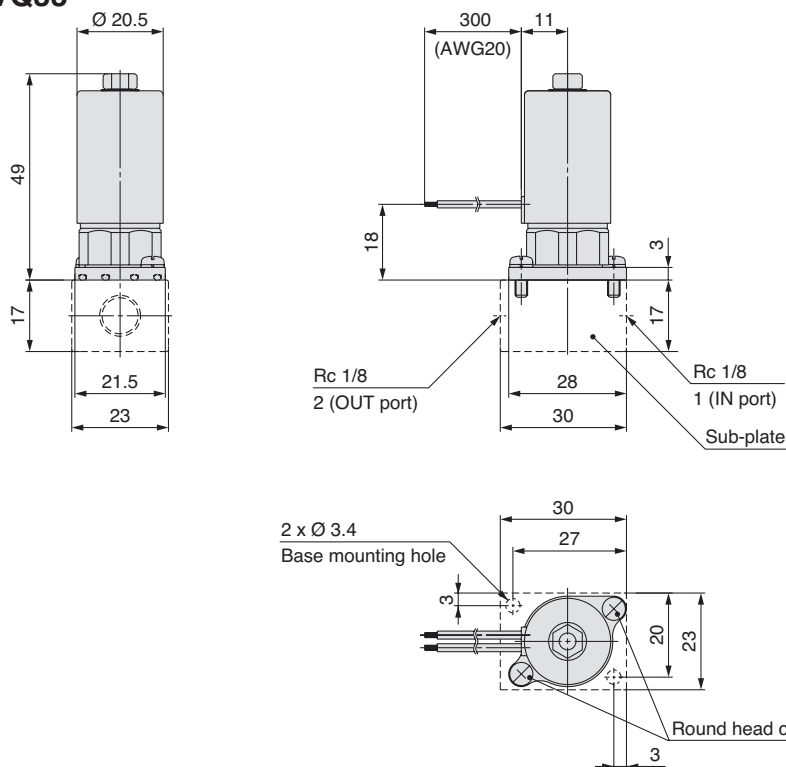

Interface

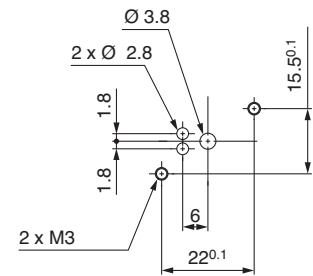

Machining dimensions of the base

Glossary

■ Proportional control

The fluid is controlled proportionally according to an input signal (current).

■ Max. operating pressure differential

Indicates the max. pressure differential (difference between the inlet and the outlet pressure) which is allowed for operation with the valve closed or open.

■ Max. operating pressure

Indicates the limit pressure that can be applied to the inlet. (The pressure differential of the proportional valve must be no more than the maximum operating pressure differential)

■ Orifice diameter

Diameter of the hole sealing the body of the proportional valve. This does not indicate the effective cross section.

■ Hysteresis

Maximum flow rate difference between the current increase and the current decrease (for the same current).
(Percentage divided by the max. flow rate)

■ Repeatability

Deviation of output flow rate when the same current is applied.
(Percentage divided by max. flow rate)

■ Start-up current

Current at which the flow rate is actually output when increasing the current from zero.
(Percentage divided by the rated current)





Series PVQ

Safety Instructions

These safety instructions are intended to prevent a hazardous situation and/or equipment damage. These instructions indicate the level of potential hazard by labels of "Caution", "Warning" or "Danger". To ensure safety, be sure to observe ISO 4414 ^{Note 1)}, JIS B 8370 ^{Note 2)} and other safety practices.

■ Explanation of the Labels

Labels	Explanation of the labels
 Danger	In extreme conditions, there is a possible result of serious injury or loss of life.
 Warning	Operator error could result in serious injury or loss of life.
 Caution	Operator error could result in injury ^{Note 3)} or equipment damage. ^{Note 4)}

Note 1) ISO 4414: Pneumatic fluid power – General rules relating to systems

Note 2) JIS B 8370: General Rules for Pneumatic Equipment

Note 3) Injury indicates light wounds, burns and electrical shocks that do not require hospitalization or hospital visits for long-term medical treatment.

Note 4) Equipment damage refers to extensive damage to the equipment and surrounding devices.

■ Selection/Handling/Applications

1. The compatibility of the pneumatic equipment is the responsibility of the person who designs the pneumatic system or decides its specifications.

Since the products specified here are used in various operating conditions, their compatibility for the specific pneumatic system must be based on specifications or post analysis and/or tests to meet the specific requirements. The expected performance and safety assurance are the responsibility of the person who has determined the compatibility of the system. This person should continuously review the suitability of all items specified, referring to the latest catalogue information with a view to giving due consideration to any possibility of equipment failure when configuring a system.

2. Only trained personnel should operate pneumatically operated machinery and equipment.

Fluids can be dangerous if handled incorrectly. Assembly, handling or repair of the systems using pneumatic equipment should be performed by trained and experienced operators.

3. Do not service machinery/equipment or attempt to remove components until safety is confirmed.

1. Inspection and maintenance of machinery/equipment should only be performed once measures to prevent falling or runaway of the driven objects have been confirmed.
2. When equipment is removed, confirm the safety process as mentioned above. Turn off the supply pressure for this equipment and exhaust all residual compressed air in the system.
3. Carefully restart the machinery, confirming that safety measures are being implemented.

4. Contact SMC if the product will be used in any of the following conditions:

1. Conditions and environments beyond the given specifications, or if product is used outdoors.
2. With fluids whose application causes concern due to the type of fluid or additives, etc.
3. An application which has the possibility of having negative effects on people and/or property, requiring special safety analysis.

■ Exemption from Liability

1. SMC, its officers and employees shall be exempted from liability for any loss or damage arising out of earthquakes or fire, action by a third person, accidents, customer error with or without intention, product misuse, and any other damages caused by abnormal operating conditions.
2. SMC, its officers and employees shall be exempted from liability for any direct or indirect loss or damage, including consequential loss or damage, loss of profits, or loss of chance, claims, demands, proceedings, costs, expenses, awards, judgments and any other liability whatsoever including legal costs and expenses, which may be suffered or incurred, whether in tort (including negligence), contract, breach of statutory duty, equity or otherwise.
3. SMC is exempted from liability for any damages caused by operations not contained in the catalogues and/or instruction manuals, and operations outside of the specification range.
4. SMC is exempted from liability for any loss or damage whatsoever caused by malfunctions of its products when combined with other devices or software.



2/3 Port Process Valves

Precautions 1

Be sure to read this before handling.

For detailed precautions on every series, refer to main text.

Design

Warning

1. Cannot be used as an emergency shutoff valve, etc.

The valves presented in this catalog are not designed for safety applications such as an emergency shutoff valve. If the valves are used in this type of system, other reliable safety assurance measures should also be adopted.

2. Extended periods of continuous energisation

Please consult SMC when using with energisation for long periods of time.

3. This solenoid valve cannot be used for explosion proof applications.

4. Maintenance space

The installation should allow sufficient space for maintenance activities (removal of the valve, etc.).

5. Actuator drive

When an actuator, such as a cylinder, is to be driven using a valve, take appropriate measures to prevent potential danger caused by actuator operation.

6. Pressure (including vacuum) holding

It is not usable for applications such as holding the pressure (including vacuum) inside of a pressure vessel because air leakage is entailed in the valve.

Selection

Warning

1. Confirm the specifications.

Give careful consideration to the operating conditions such as the application, fluid and environment, and use within the operating ranges specified in this catalogue.

2. Fluid

1) Gas

Refer to specification for internal/external leakage.

2) Corrosive gas

Cannot be used since it will lead to cracks by stress corrosion or result in other incidents.

3. Fluid quality

The use of a fluid which contains foreign matter can cause malfunction and seal failure. These problems are due to wear of the valve seat and armature, and sticking to the sliding parts of the armature. Install a suitable filter (strainer) immediately upstream from the valve. As a general rule, use 80 to 100 mesh.

Selection

Warning

4. Air quality

1) Use clean air.

Do not use compressed air which includes chemicals, synthetic oils containing organic solvents, salt or corrosive gases, etc., as it can cause damage or malfunction.

2) Install air filters.

Install air filters close to the valves at their upstream side. A nominal filtration rating of 5 μ m or less should be selected.

3) Install an air dryer or after-cooler, etc.

Compressed air that includes excessive drainage may cause malfunction of the valves and other pneumatic equipment. To prevent this, install an air dryer or after-cooler, etc.

4) If excessive carbon powder is generated, eliminate it by installing mist separators at the upstream side of the valves.

If excessive carbon powder is generated by the compressor, it may adhere to the inside of the valves and cause a malfunction.

Refer to SMC's "Best Pneumatics" catalogue for further details on compressed air quality.

5. Ambient environment

Use within the operable ambient temperature range. Confirm the compatibility between the product's composition materials and the ambient atmosphere. Be sure that the used fluid does not touch the external surface of the product.

6. Countermeasures against static electricity

Take actions to prevent static electricity since some fluids may cause static electricity.

Caution

1. Leakage voltage

Particularly when using a resistor in parallel with a switching element and using a C-R element (surge voltage suppressor) to protect the switching element, take note that leakage current will flow through the resistor, C-R element, etc., creating a possible danger that the valve may not turn off.

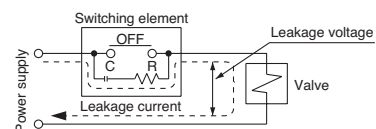

DC coil: 2 % or less of rated voltage



2/3 Port Process Valves Precautions 2

Be sure to read this before handling.

For detailed precautions on every series, refer to main text.

Mounting

Warning

1. If air leakage increases or the equipment does not operate properly, stop operation.

After mounting is completed, confirm that it has been done correctly by performing a suitable function test.

2. Do not apply external forces to the coil section.

When tightening is performed, apply a wrench or other tool to the outside of the piping connection parts.

3. Do not warm the coil assembly with a heat insulator, etc.

Use tape, heaters, etc., to prevent freezing on the piping and body only. They can cause the coil to burn out.

4. Secure with brackets, except in the case of steel piping and copper fittings.

5. Avoid sources of vibration or adjust the arm from the body to the minimum length so that resonance will not occur.

6. Instruction manual

The product should be mounted and operated after the instruction manual is thoroughly read and its contents are understood. Keep the instruction manual where it can be referred to as needed.

7. Painting and coating

Warnings or specifications printed or labeled on the product should not be erased, removed or covered up.

Piping

Caution

1. Preparation before piping

Before piping is connected, it should be thoroughly blown out with air (flushing) or washed to remove chips, cutting oil and other debris from inside the pipe. Avoid pulling, compressing or bending the valve body when piping.

2. Wrapping of pipe tape

When connecting pipes, fittings, etc., be sure that chips from the pipe threads and sealing material do not enter the valve.

Furthermore, when pipe tape is used, leave 1.5 to 2 thread ridges exposed at the end of the threads.

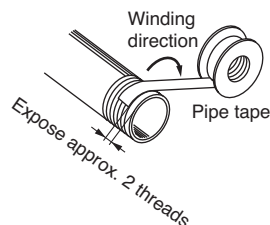

3. Avoid connecting ground lines to piping, as this may cause electric corrosion of the system.

Piping

Caution

4. Always tighten threads with the proper tightening torque.

When attaching fittings to valves, tighten with the proper tightening torque shown below.

Tightening Torque for Piping

Connection threads	Proper tightening torque N·m
M5	1.5 to 2
Rc 1/8	7 to 9

* Reference

Tightening of M5 fitting threads

After tightening by hand, tighten approximately 1/6 turn further with a tightening tool. However, when using miniature fittings, tighten an additional 1/4 turn after tightening by hand. (In cases where there are gaskets in two places, such as a universal elbow or universal tee, double the additional tightening to 1/2 turn.)

5. Connection of piping to products

When connecting piping to a product, refer to its instruction manual to avoid mistakes regarding the supply port, etc.

Wiring

Caution

1. As a rule, use electrical wire with a cross sectional area of 0.5 to 1.25 mm² for wiring.

Furthermore, do not allow excessive force to be applied to the lines.

2. Use electrical circuits which do not generate chattering in their contacts.

3. Use voltage which is within 10 % of the rated voltage.

When using a DC power supply where importance is placed on responsiveness, stay within 5 % of the rated value. The voltage drop is the value in the lead wire section connecting the coil.

4. When a surge from the solenoid affects the electrical circuitry, install a surge absorber, etc., in parallel with the solenoid.



2/3 Port Process Valves Precautions 3

Be sure to read this before handling.

For detailed precautions on every series, refer to main text.

Operating Environment

Warning

1. Do not use the valves in an atmospheres having corrosive gases, chemicals, salt water, water, steam, or where there is direct contact with any of these.
2. Do not use in explosive atmospheres.
3. Do not use in locations subject to vibration or impact.
4. Do not use in locations where radiated heat will be received from nearby heat sources.
5. Employ suitable protective measures in locations where there is contact with water droplets, oil or welding spatter, etc.

Lubrication

Caution

1. This solenoid valve can be operated without lubrication.

If a lubricant is used in the system, use turbine oil Class 1, ISO VG32 (with no additives).

In order to select the proper lubricant, refer to the table below [Brand names of Class 1 turbine oils (With no additives) compliant with ISO VG32].

Class 1 Turbine Oil (with no additive), ISO VG32

Classification of viscosity (cst) (40C)	Viscosity according to ISO Grade	32
Idemitsu Kosan Co.,Ltd.		Turbine oil P-32
Nippon Oil Corp.		Turbine oil 32
Cosmo Oil Co.,Ltd.		Cosmo turbine 32
Japan Energy Corp.		Kyodo turbine 32
Kygnus Oil Co.		Turbine oil 32
Kyushu Oil Co.		Stork turbine 32
Nippon Oil Corp.		Mitsubishi turbine 32
Showa Shell Sekiyu K.K.		Turbine 32
Tonen General Sekiyu K.K.		General R turbine 32
Fuji Kosan Co.,Ltd.		Fucoal turbine 32

Please contact SMC regarding Class 2 turbine oil (with additives), ISO VG32.

Maintenance

Warning

1. Removing the product

1. Shut the fluid supply off and release the fluid pressure in the system.
2. Shut the power supply off.
3. Dismount the product.

2. Low frequency operation

Switch valves at least once every 30 days to prevent malfunction. Also, in order to use it under the optimum state, conduct a regular inspection every 6 months.

3. Do not disassemble the product. Products which have been disassembled cannot be guaranteed.

If disassembly is necessary, please contact SMC.

Caution

1. Filters and strainers

1. Be careful regarding clogging of filters and strainers.
2. Replace filter elements after one year of use, or earlier if the pressure drop reaches 0.1 MPa.
3. Clean strainers when the pressure drop reaches 0.1 MPa.

2. Exhaust the drain from an air filter periodically.



PVQ Series Specific Product Precautions

Be sure to read this before handling the products.
Refer to back page 50 for Safety Instructions.

Power Source Selection

⚠ Caution

This product makes proportional control possible with constant current.

If controlled with voltage, the output flow rate cannot be kept constant due to current fluctuation. Use stable DC power source of sufficient capacity without much ripple.

Handling

⚠ Caution

1. This product is adjusted to the respective specifications at SMC factory before delivery.

Do not disassemble the product or remove parts as it could cause breakdown of the product.

2. Flow rate is controlled by balancing the valve body.

Do not expose the product to external vibration and impact as it changes the flow rate.

Vibration may occur depending on the piping conditions or control methods.

Pressure Difference

⚠ Caution

Leakage from the valve may be caused if the pressure difference is larger than the maximum operating pressure differential of the respective models.

Flow Rate

⚠ Caution

Flow rate varies depending on model differences and piping conditions. Select the model that fully satisfies the necessary flow rate based on the flow rate characteristics graphs.

Operation in Vacuum

⚠ Caution

When the product is used in vacuum, apply vacuum pressure to A (2) port.

The pressure at P(1) port should be larger than the pressure at A(2) port.

Valve Mounting

⚠ Caution

When mounting a valve to the sub-plate, tighten the screw securely with the tightening torque shown in the table below after checking the installation condition of the O-ring on the interface side.

Proper Tightening Torque (NNm)

PVQ10 (Base mounted)	PVQ30 (Base mounted)
0.15 to 0.22	0.8 to 1.0

Continuous Energization

⚠ Warning

1. Ambient temperature and outer surface temperature

When the valve is continuously energized (when applying maximum current) and the ambient temperature is kept at 50 °C due to the convection of the air around the valve, the coil outer surface reaches approximately 90 °C for the PVQ10 series and 100 °C for the PVQ30 series.

The valve proximal section (approx. 1 mm) reaches approximately 60 °C for the PVQ10 series and 70 °C for the PVQ30 series.

When the valve is mounted inside the enclosed control panel (in a state without convection of air), however, the above temperature may be exceeded due to the rise in coil temperature or the influence of other equipment. Take measures to release the heat, for example, to create a convection of the air around the valve or provide an air vent.

2. Do not touch the valve directly with hands. The coil can be hot depending on the ambient temperature or energizing time.

Install a protective cover over the valve if it can be touched directly with hands.

Model Selection

⚠ Caution

1. For this product, the max. operating pressure differential varies by orifice diameter.

Operate at a pressure differential which is 20 % or more of the max. operating pressure differential.

If the product must be operated at a pressure differential which is less than 20 % of the max. operating pressure differential, either change the size of the orifice or change to a size from the PVQ10 series.

2. The smaller the pressure differential the product is operating at is in relation to the max. operating pressure differential, the smaller the controllable flow rate range and electric current range will be. This may result in reduced controllability, and hunting phenomenon or valve opening failure may occur.

3. If this product is used for the charging and discharging of a tank, the valve pressure differential may get smaller due to pressure fluctuations in the tank, which may result in valve opening failure.

Safety Instructions

These safety instructions are intended to prevent hazardous situations and/or equipment damage. These instructions indicate the level of potential hazard with the labels of “**Caution**,” “**Warning**” or “**Danger**.” They are all important notes for safety and must be followed in addition to International Standards (ISO/IEC) ¹⁾, and other safety regulations.

Danger:

Danger indicates a hazard with a high level of risk which, if not avoided, will result in death or serious injury.

Warning:

Warning indicates a hazard with a medium level of risk which, if not avoided, could result in death or serious injury.

Caution:

Caution indicates a hazard with a low level of risk which, if not avoided, could result in minor or moderate injury.

- 1) ISO 4414: Pneumatic fluid power – General rules and safety requirements for systems and their components.
- ISO 4413: Hydraulic fluid power – General rules and safety requirements for systems and their components.
- IEC 60204-1: Safety of machinery – Electrical equipment of machines. (Part 1: General requirements)
- ISO 10218-1: Robots and robotic devices - Safety requirements for industrial robots - Part 1: Robots.
- etc.

Warning

1. The compatibility of the product is the responsibility of the person who designs the equipment or decides its specifications.

Since the product specified here is used under various operating conditions, its compatibility with specific equipment must be decided by the person who designs the equipment or decides its specifications based on necessary analysis and test results. The expected performance and safety assurance of the equipment will be the responsibility of the person who has determined its compatibility with the product. This person should also continuously review all specifications of the product referring to its latest catalogue information, with a view to giving due consideration to any possibility of equipment failure when configuring the equipment.

2. Only personnel with appropriate training should operate machinery and equipment.

The product specified here may become unsafe if handled incorrectly. The assembly, operation and maintenance of machines or equipment including our products must be performed by an operator who is appropriately trained and experienced.

3. Do not service or attempt to remove product and machinery/equipment until safety is confirmed.

1. The inspection and maintenance of machinery/equipment should only be performed after measures to prevent falling or runaway of the driven objects have been confirmed.
2. When the product is to be removed, confirm that the safety measures as mentioned above are implemented and the power from any appropriate source is cut, and read and understand the specific product precautions of all relevant products carefully.
3. Before machinery/equipment is restarted, take measures to prevent unexpected operation and malfunction.

4. Our products cannot be used beyond their specifications. Our products are not developed, designed, and manufactured to be used under the following conditions or environments.

Use under such conditions or environments is not covered.

1. Conditions and environments outside of the given specifications, or use outdoors or in a place exposed to direct sunlight.
2. Use for nuclear power, railways, aviation, space equipment, ships, vehicles, military application, equipment affecting human life, body, and property, fuel equipment, entertainment equipment, emergency shut-off circuits, press clutches, brake circuits, safety equipment, etc., and use for applications that do not conform to standard specifications such as catalogues and operation manuals.
3. Use for interlock circuits, except for use with double interlock such as installing a mechanical protection function in case of failure. Please periodically inspect the product to confirm that the product is operating properly.

Caution

We develop, design, and manufacture our products to be used for automatic control equipment, and provide them for peaceful use in manufacturing industries.

Use in non-manufacturing industries is not covered.

Products we manufacture and sell cannot be used for the purpose of transactions or certification specified in the Measurement Act.

The new Measurement Act prohibits use of any unit other than SI units in Japan.

Limited warranty and Disclaimer/Compliance Requirements

The product used is subject to the following “Limited warranty and Disclaimer” and “Compliance Requirements”. Read and accept them before using the product.

Limited warranty and Disclaimer

1. The warranty period of the product is 1 year in service or 1.5 years after the product is delivered, whichever is first. ²⁾ Also, the product may have specified durability, running distance or replacement parts. Please consult your nearest sales branch.
2. For any failure or damage reported within the warranty period which is clearly our responsibility, a replacement product or necessary parts will be provided. This limited warranty applies only to our product independently, and not to any other damage incurred due to the failure of the product.
3. Prior to using SMC products, please read and understand the warranty terms and disclaimers noted in the specified catalogue for the particular products.
- 2) Vacuum pads are excluded from this 1 year warranty. A vacuum pad is a consumable part, so it is warranted for a year after it is delivered. Also, even within the warranty period, the wear of a product due to the use of the vacuum pad or failure due to the deterioration of rubber material are not covered by the limited warranty.

Compliance Requirements

1. The use of SMC products with production equipment for the manufacture of weapons of mass destruction (WMD) or any other weapon is strictly prohibited.
2. The exports of SMC products or technology from one country to another are governed by the relevant security laws and regulations of the countries involved in the transaction. Prior to the shipment of a SMC product to another country, assure that all local rules governing that export are known and followed.

Safety Instructions

Be sure to read “Handling Precautions for SMC Products” (M-E03-3) before using.

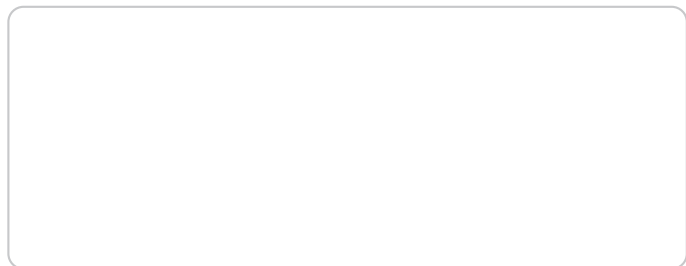

SMC Corporation (Europe)

Austria	+43 (0)2262622800	www.smc.at	office.at@smc.com
Belgium	+32 (0)33551464	www.smc.be	info@smc.be
Bulgaria	+359 (0)2807670	www.smc.bg	sales.bg@smc.com
Croatia	+385 (0)13707288	www.smc.hr	sales.hr@smc.com
Czech Republic	+420 541424611	www.smc.cz	office.at@smc.com
Denmark	+45 70252900	www.smc.dk.com	smc.dk@smc.com
Estonia	+372 651 0370	www.smcee.ee	info.ee@smc.com
Finland	+358 207513513	www.smc.fi	smc.fi@smc.com
France	+33 (0)164761000	www.smc-france.fr	supportclient.fr@smc.com
Germany	+49 (0)61034020	www.smc.de	info.de@smc.com
Greece	+30 210 2717265	www.smchellas.gr	sales@smchellas.gr
Hungary	+36 23513000	www.smc.hu	office.hu@smc.com
Ireland	+353 (0)14039000	www.smcautomation.ie	technical.ie@smc.com
Italy	+39 03990691	www.smcitalia.it	mailbox.it@smc.com
Latvia	+371 67817700	www.smc.lv	info.lv@smc.com

Lithuania	+370 5 2308118	www.smclt.lt	info.lt@smc.com
Netherlands	+31 (0)205318888	www.smc.nl	info@smc.nl
Norway	+47 67129020	www.smc-norge.no	post.no@smc.com
Poland	+48 22 344 40 00	www.smc.pl	office.pl@smc.com
Portugal	+351 214724500	www.smc.eu	apoiocliente.pt@smc.com
Romania	+40 213205111	www.smcromania.ro	office.ro@smc.com
Russia	+7 (812)3036600	www.smc.eu	sales@smcru.com
Slovakia	+421 (0)413213212	www.smc.sk	sales.sk@smc.com
Slovenia	+386 (0)73885412	www.smc.si	office.si@smc.com
Spain	+34 945184100	www.smc.eu	post.es@smc.com
Sweden	+46 (0)86031240	www.smc.nu	order.se@smc.com
Switzerland	+41 (0)523963131	www.smc.ch	helpcenter.ch@smc.com
Turkey	+90 212 489 0 440	www.smcturkey.com.tr	satis.tr@smc.com
UK	+44 (0)845 121 5122	www.smc.uk	sales.gb@smc.com

South Africa	+27 10 900 1233	www.smcza.co.za	Sales.za@smc.com
---------------------	-----------------	-----------------	------------------