

Construction

AMG150C to 550C, AMG650

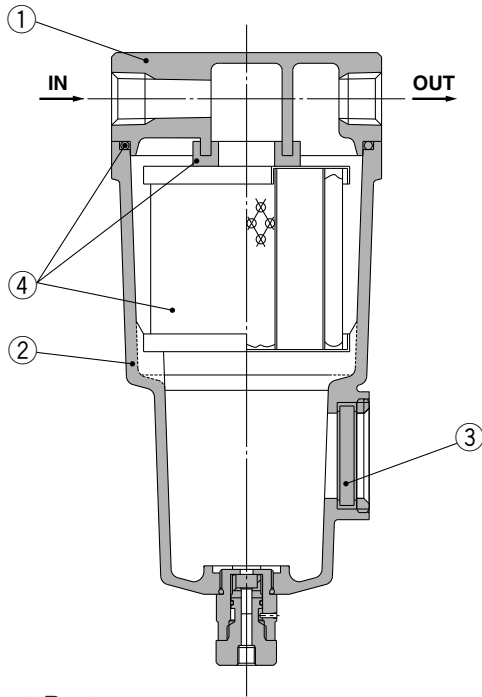

AMG850

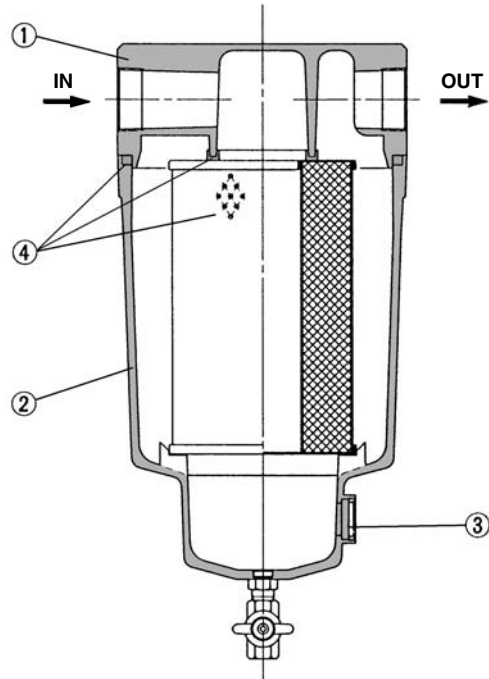

Component Parts

No.	Description	Material	Note
1	Body	Aluminum die-casted	Chrome treated Epoxy coating on inner surface
2	Housing	Aluminum die-casted*	
3	Sight glass	Tempered glass	—

* The AMG850 is aluminum casted.



Note) Refer to "How to Order Bowl Assembly" on page 63.



Note) Sight glass is indicated in the figure for easy understanding of component parts. However, it differs from the actual construction. Refer to dimensions on pages 7 through to 9 for details.

Replacement Parts

No.	Description	Material	Applicable model	Model						
				AMG150C	AMG250C	AMG350C	AMG450C	AMG550C	AMG650	AMG850
4	Element assembly	Resin, others	Except option F	AMG-EL150	AMG-EL250	AMG-EL350	AMG-EL450	AMG-EL550	AMG-EL650	AMG-EL850
			For option F	AMG-EL150-F	AMG-EL250-F	AMG-EL350-F	AMG-EL450-F	AMG-EL550-F	—	—

* Element assembly: With gasket (1 pc.) and O-ring (1 pc.)

* Refer to back page 6 for replacement of auto drain.

* Element assemblies for Made to Order (X12, X15, X20, X26) are same as those for standard (see the above table).

Maximum Air Flow

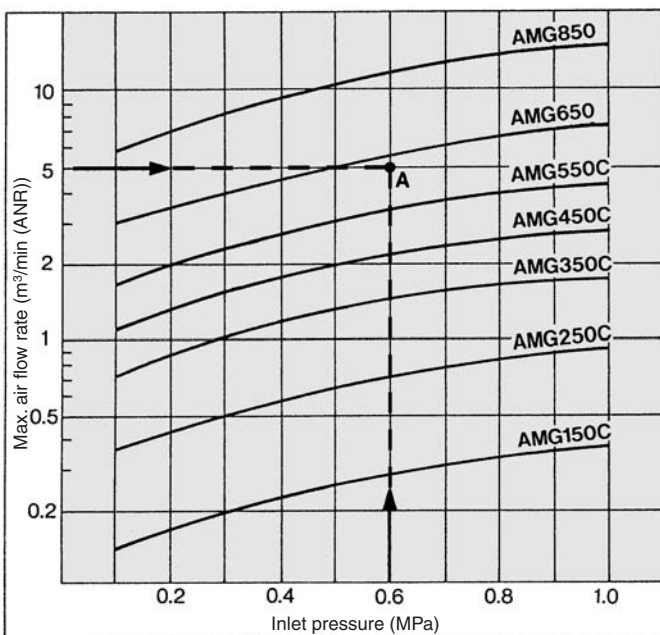

Model Selection

Select a model in accordance with the following procedure taking the inlet pressure and the max. air flow rate into consideration.

(Example) Inlet pressure: 0.6 MPa

Max. air flow rate: 5 m³/min (ANR)

1. Obtain the intersecting point A of inlet pressure and max. air flow rate in the graph.
2. The AMG650 is obtained when the max. flow line is above the intersecting point A in the graph.



Note) Make sure to select a model that has the max. flow line above the obtained intersecting point. With a model that has the max. flow line below the obtained intersecting point, the flow rate will be exceeded, thus leading to a problem such as being unable to satisfy the specifications.