



**U.S. Tsubaki Power Transmission, LLC**

301 E. Marquardt Dr.

Wheeling, IL 60090

**Phone:** 847.459.9500 or 800.323.7790

**Fax:** 847.459.9515

**Email:** [sales@ustsubaki.com](mailto:sales@ustsubaki.com)

**Website:** [www.ustsubaki.com](http://www.ustsubaki.com)

## ITEM # BSEU40-40, BSEU40-40 MM BORE CAM CLUTCH

BSEU Series Cam Clutch was developed as a user-friendly backstopping Cam Clutch. It has cam and roller construction which is the same as the smaller size BS Series Cam Clutch. The outer race has a special shape which combines the torque arm providing easy installation. These Cam Clutches are shipped pre-lubricated with grease and ready for installation. Most often used as a backstop in applications where limited space is available.

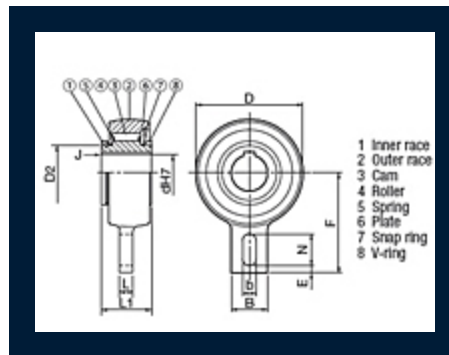

### Specifications

<b>Torque Capacity</b>	1062.0 lb·ft 1440.0 N·m
<b>Max. Overrunning Speed</b>	450 rpm
<b>Bore Size</b>	1.575 in 40.00 mm
<b>Inner Race Keyway</b>	12 x 3.3 mm

<b>D (Diameter)</b>	4.646 in 118.00 mm
<b>D2</b>	2.362 in 60.00 mm
<b>L1 (Overall Width)</b>	2.165 in 55.00 mm
<b>L (Width)</b>	0.591 in 15.00 mm
<b>B (Tab Width)</b>	1.575 in 40.00 mm
<b>F (End to Center-Line)</b>	4.331 in 110.00 mm
<b>b (Slot Width)</b>	0.591 in 15.00 mm
<b>N (Slot Height)</b>	1.378 in 35.00 mm
<b>E</b>	0.315 in 8.00 mm
<b>J (Chamfer)</b>	0.059 in 1.50 mm
<b>Weight (Approx.)</b>	8.360 lb 3.800 kg